

P'0395

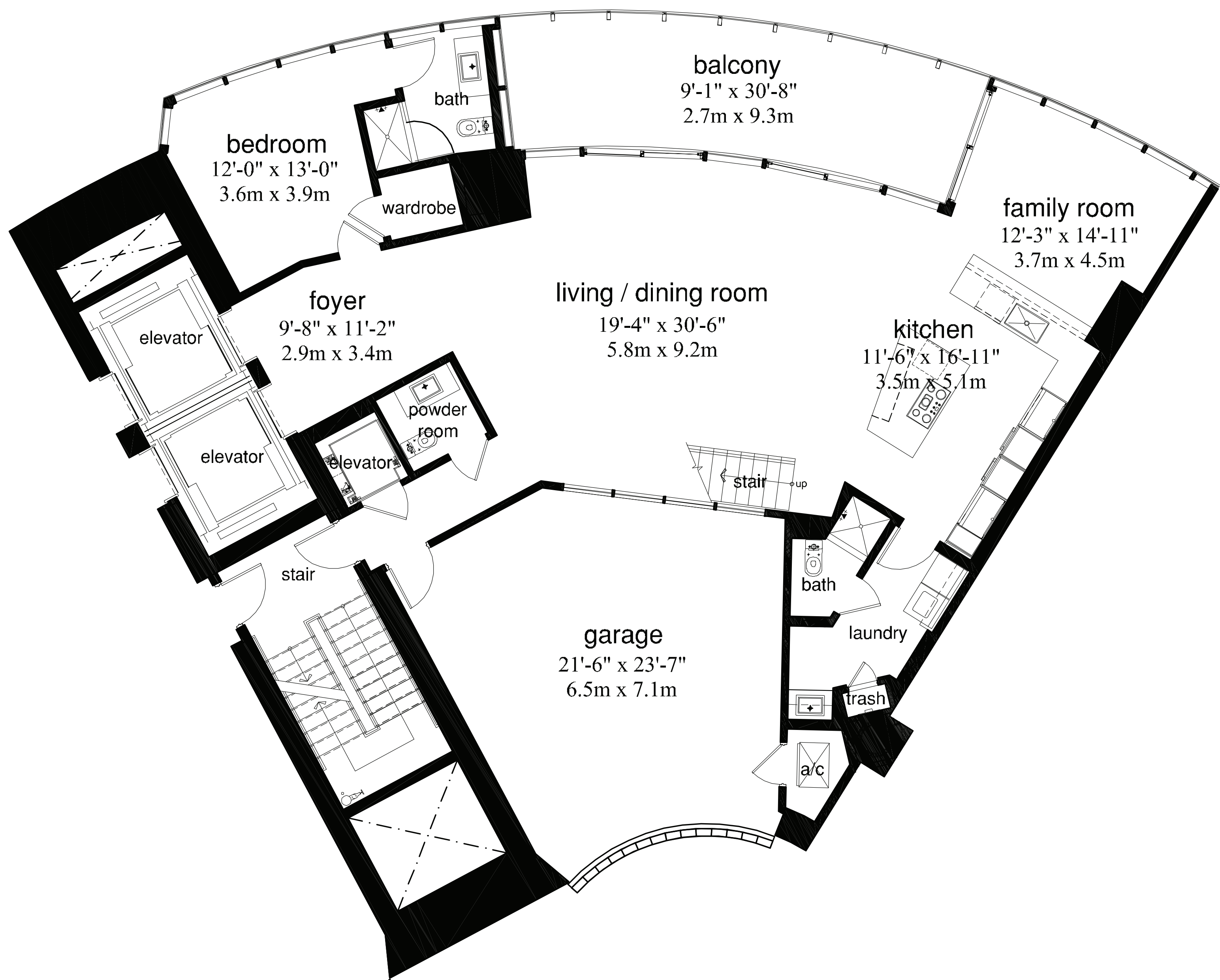

Area	Lower [SQ FT M ²]	Upper [SQ FT M ²]	Total [SQ FT M ²]
Interior	1,846 171.4	1,576 146.4	3,422 317.9
Balcony	288 26.7		288 26.7
Garage	542 50.3		542 50.3
Total	2,676 248.4		4,252 394.9

These drawings are conceptual only and are for the convenience of reference. They should not be relied upon as representations, express or implied, of the final detail of the residences. Units shown are examples of unit types and may not depict actual units. Stated square footages are ranges for a particular unit type and are measured to the exterior boundaries of the exterior walls and the centerline of interior demising walls and in fact vary from the area that would be determined by using the description and definition of the "Unit" set forth in the Declaration [which generally only includes the interior airspace between the perimeter walls and excludes interior structural components]. All depictions of appliances, plumbing fixtures, equipment, counters, soffits, floor coverings and other matters of detail are conceptual only and are not necessarily included in each Unit. Consult your Agreement and the Prospectus for the items included with the Unit. Dimensions and square footage are approximate, will vary with specific unit type, and may vary with actual construction. Additionally, measurements of rooms set forth on any floor plan are nominal and generally taken at the greatest points of each given room [as if the room were a perfect rectangle], without regard for any cutouts. Unit orientation and windows [including number, size, orientation and awnings], balcony/lanais [including configuration, size and railing/balustrade], structure and mechanical chases may vary. The developer expressly reserves the right to make modifications, revisions, and changes it deems desirable in its sole and absolute discretion and without notice.

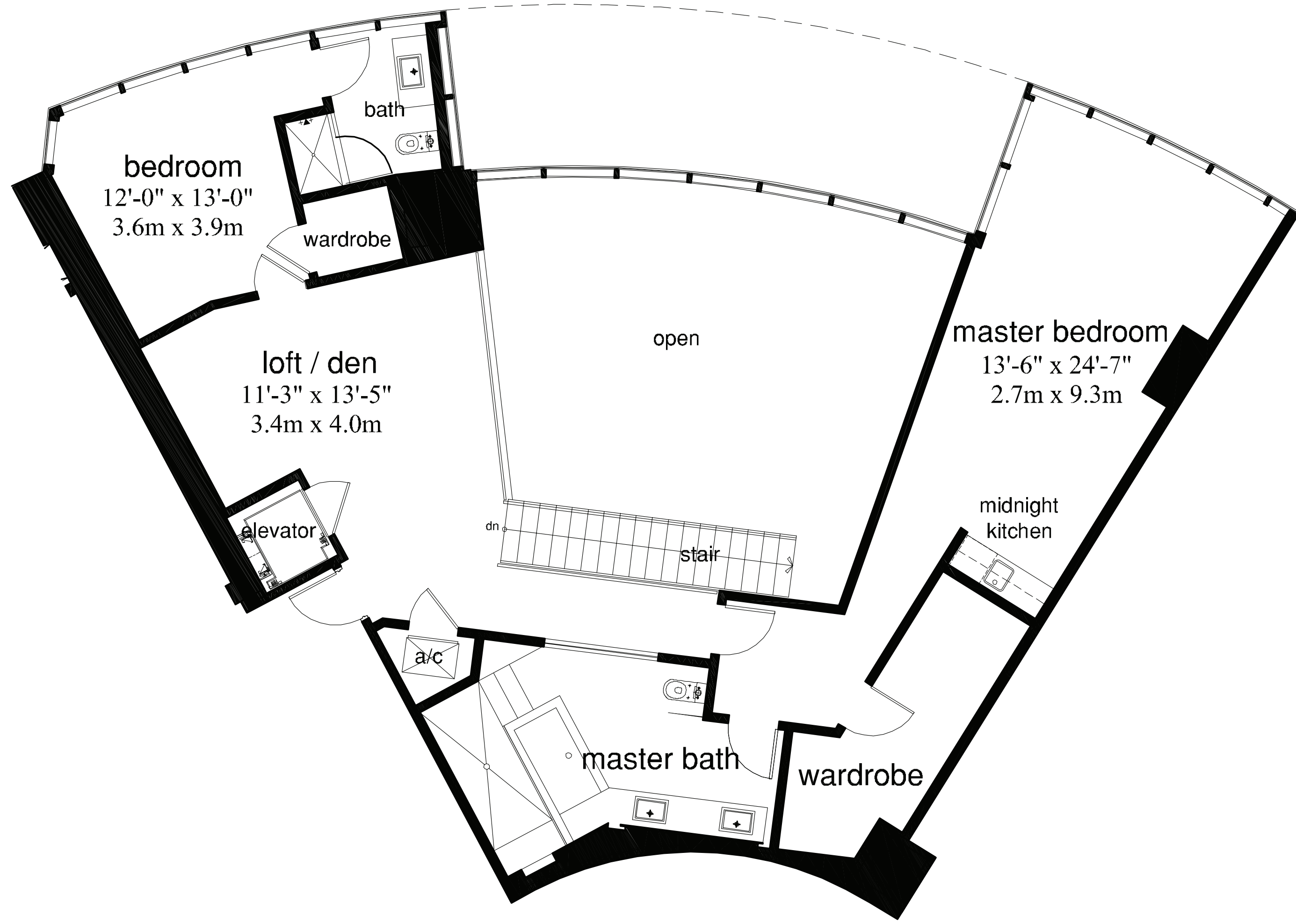
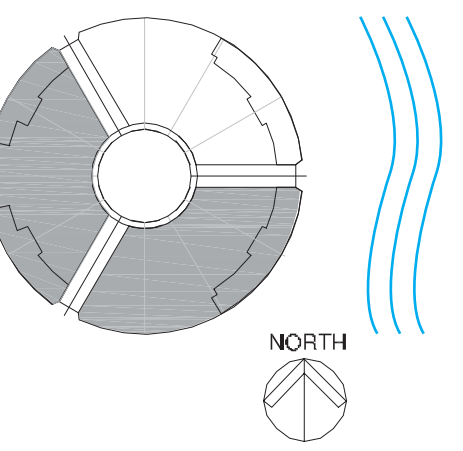

P'0441

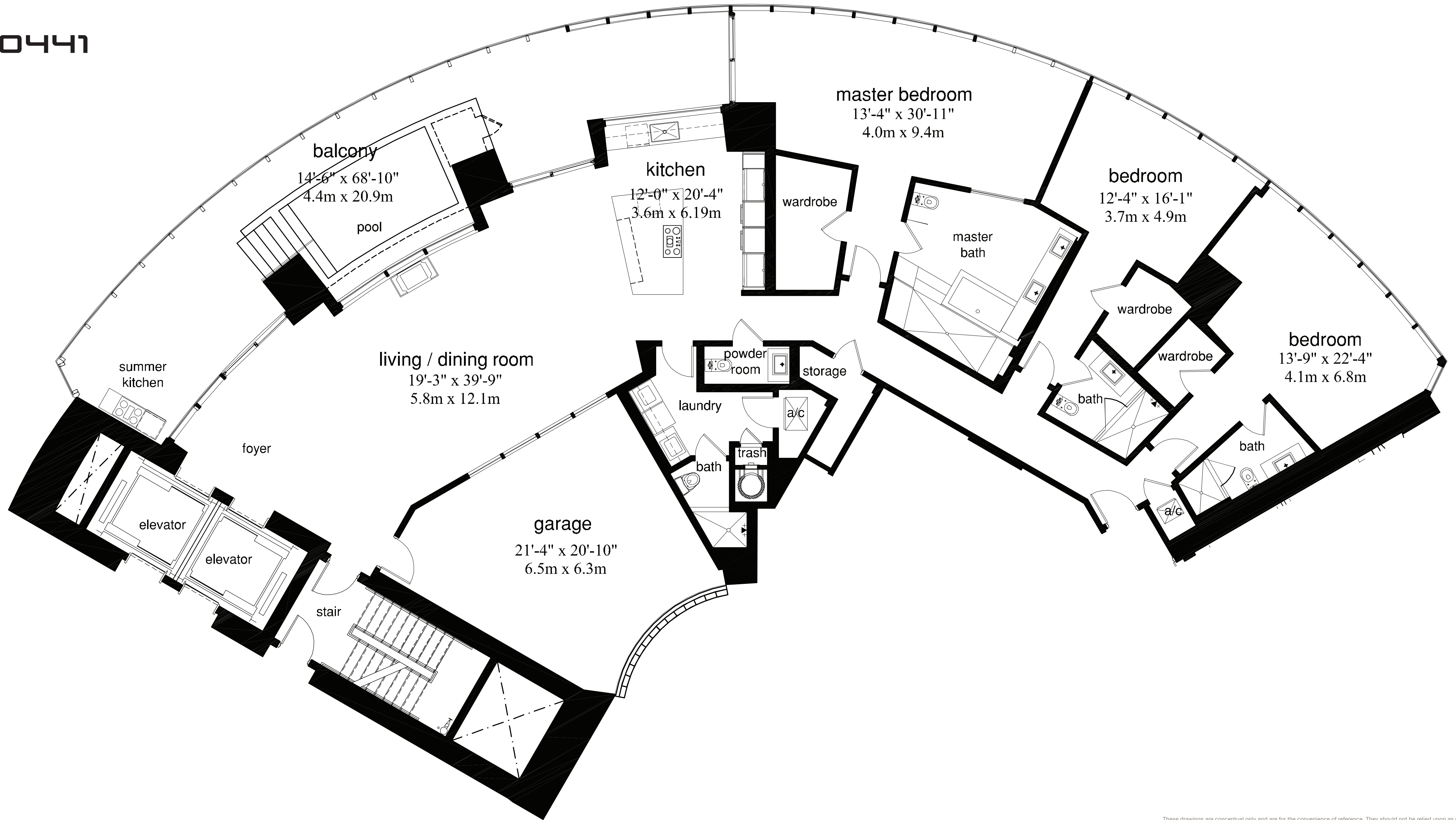

Area	SQ FT	M ²
Interior	3,415	317.2
Balcony	831	77.2
Garage	503	46.7
Total	4,749	441.1

These drawings are conceptual only and are for the convenience of reference. They should not be relied upon as representations, express or implied, of the final detail of the residences. Units shown are examples of unit types and may not depict actual units. Stated square footages are ranges for a particular unit type and are measured to the exterior boundaries of the exterior walls and the centerline of interior demising walls and in fact vary from the area that would be determined by using the description and definition of the "Unit" set forth in the Declaration [which generally only includes the interior airspace between the perimeter walls and excludes interior structural components]. All depictions of appliances, plumbing fixtures, equipment, counters, soffits, floor coverings and other matters of detail are conceptual only and are not necessarily included in each Unit. Consult your Agreement and the Prospectus for the items included with the Unit. Dimensions and square footage are approximate, will vary with specific unit type, and may vary with actual construction. Additionally, measurements of rooms set forth on any floor plan are nominal and generally taken at the greatest points of each given room [as if the room were a perfect rectangle], without regard for any cutouts. Unit orientation and windows (including number, size, orientation and awnings), balcony/lanais (including configuration, size and railing/balustrade), structure and mechanical chases may vary. The developer expressly reserves the right to make modifications, revisions, and changes it deems desirable in its sole and absolute discretion and without notice.

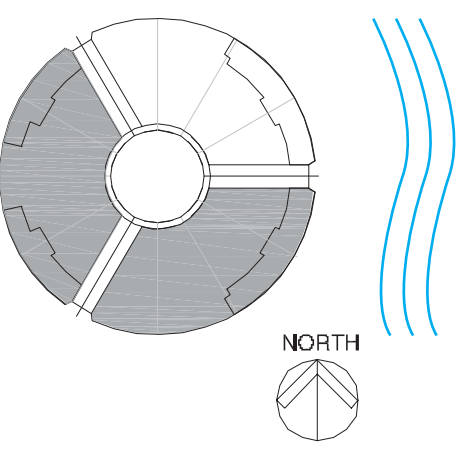

P'0481

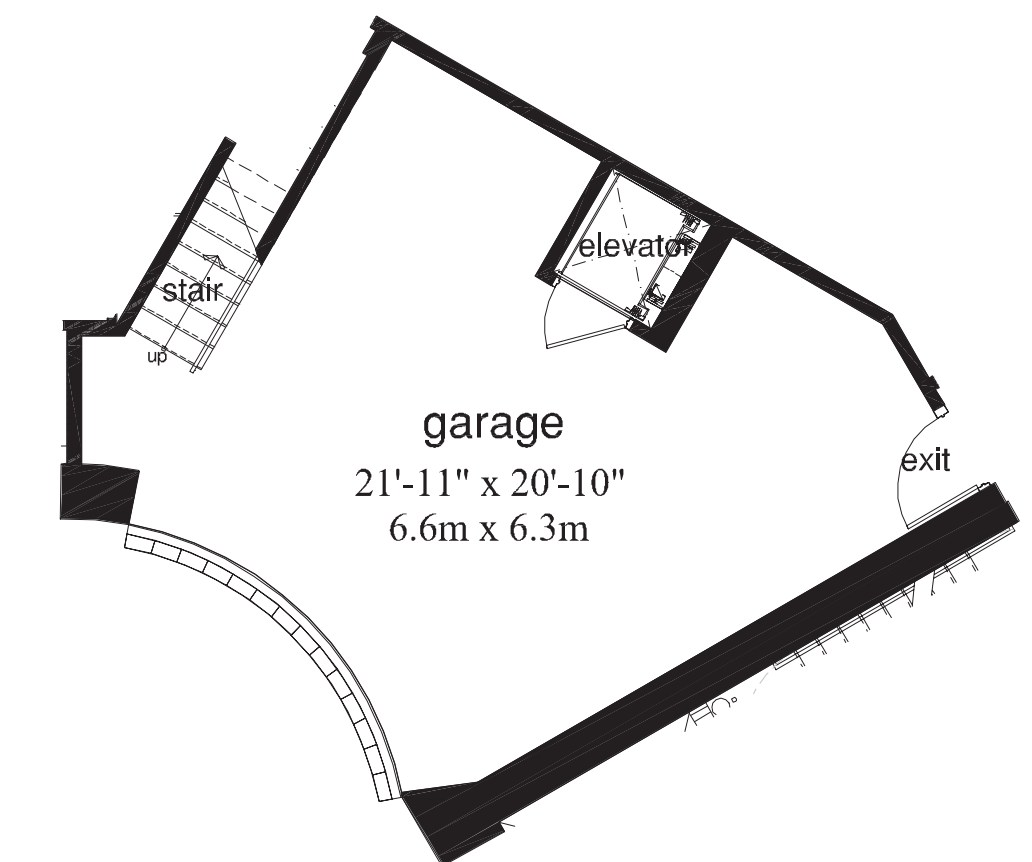
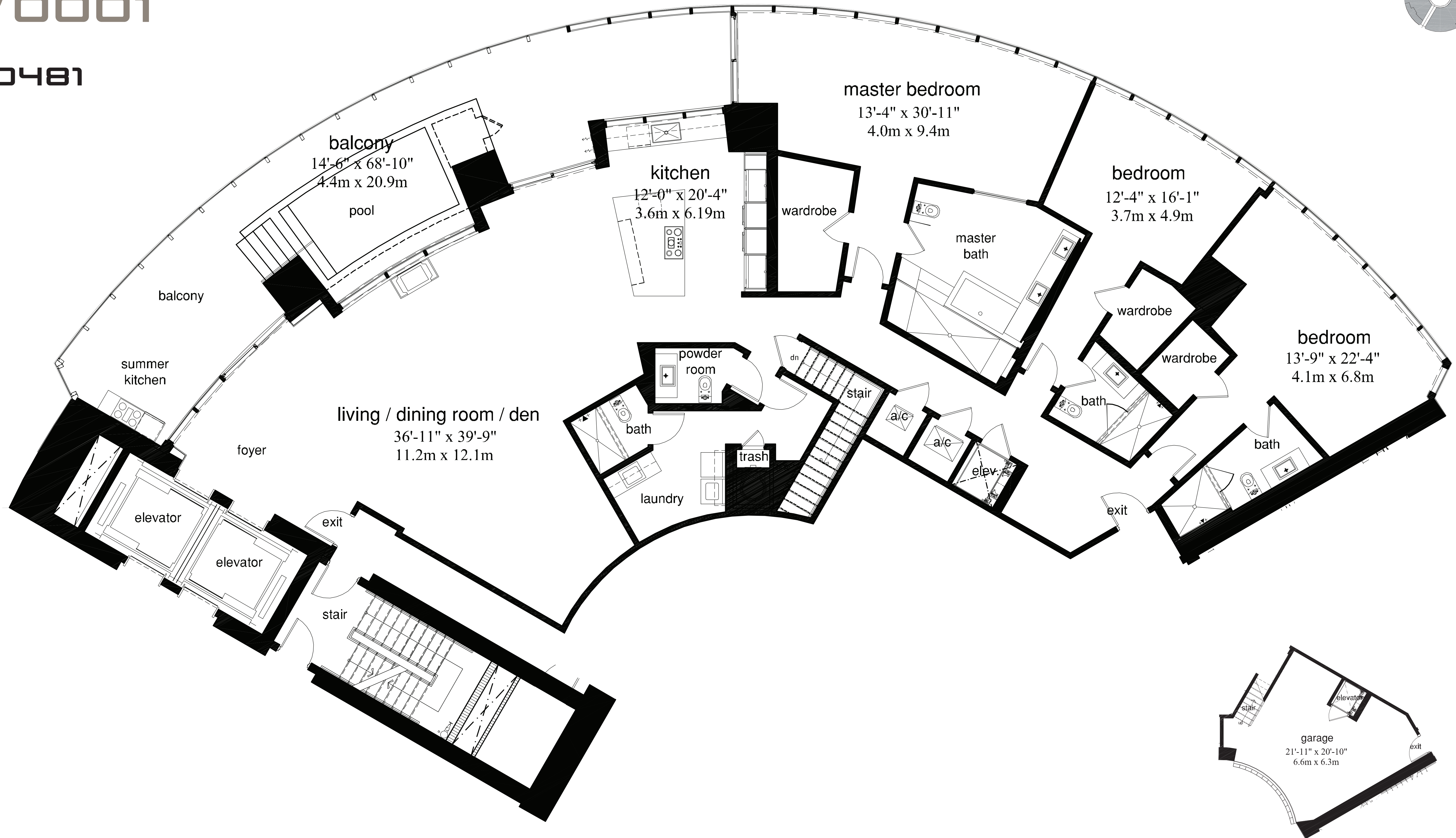

Area	SQ FT	M ²
Interior	3,785	351.6
Balcony	831	77.2
Garage	569	52.8
Total	5,185	481.6

These drawings are conceptual only and are for the convenience of reference. They should not be relied upon as representations, express or implied, of the final detail of the residences. Units shown are examples of unit types and may not depict actual units. Stated square footages are ranges for a particular unit type and are measured to the exterior boundaries of the exterior walls and the centerline of interior demising walls and in fact vary from the area that would be determined by using the description and definition of the "Unit" set forth in the Declaration [which generally only includes the interior airspace between the perimeter walls and excludes interior structural components]. All depictions of appliances, plumbing fixtures, equipment, counters, soffits, floor coverings and other matters of detail are conceptual only and are not necessarily included in each Unit. Consult your Agreement and the Prospectus for the items included with the Unit. Dimensions and square footage are approximate, will vary with specific unit type, and may vary with actual construction. Additionally, measurements of rooms set forth on any floor plan are nominal and generally taken at the greatest points of each given room [as if the room were a perfect rectangle], without regard for any cutouts. Unit orientation and windows [including number, size, orientation and awnings], balcony/lanais [including configuration, size and railing/balustrade], structure and mechanical chases may vary. The developer expressly reserves the right to make modifications, revisions, and changes it deems desirable in its sole and absolute discretion and without notice.

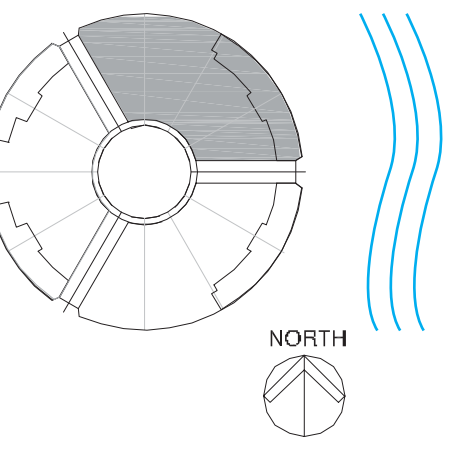

P'0550

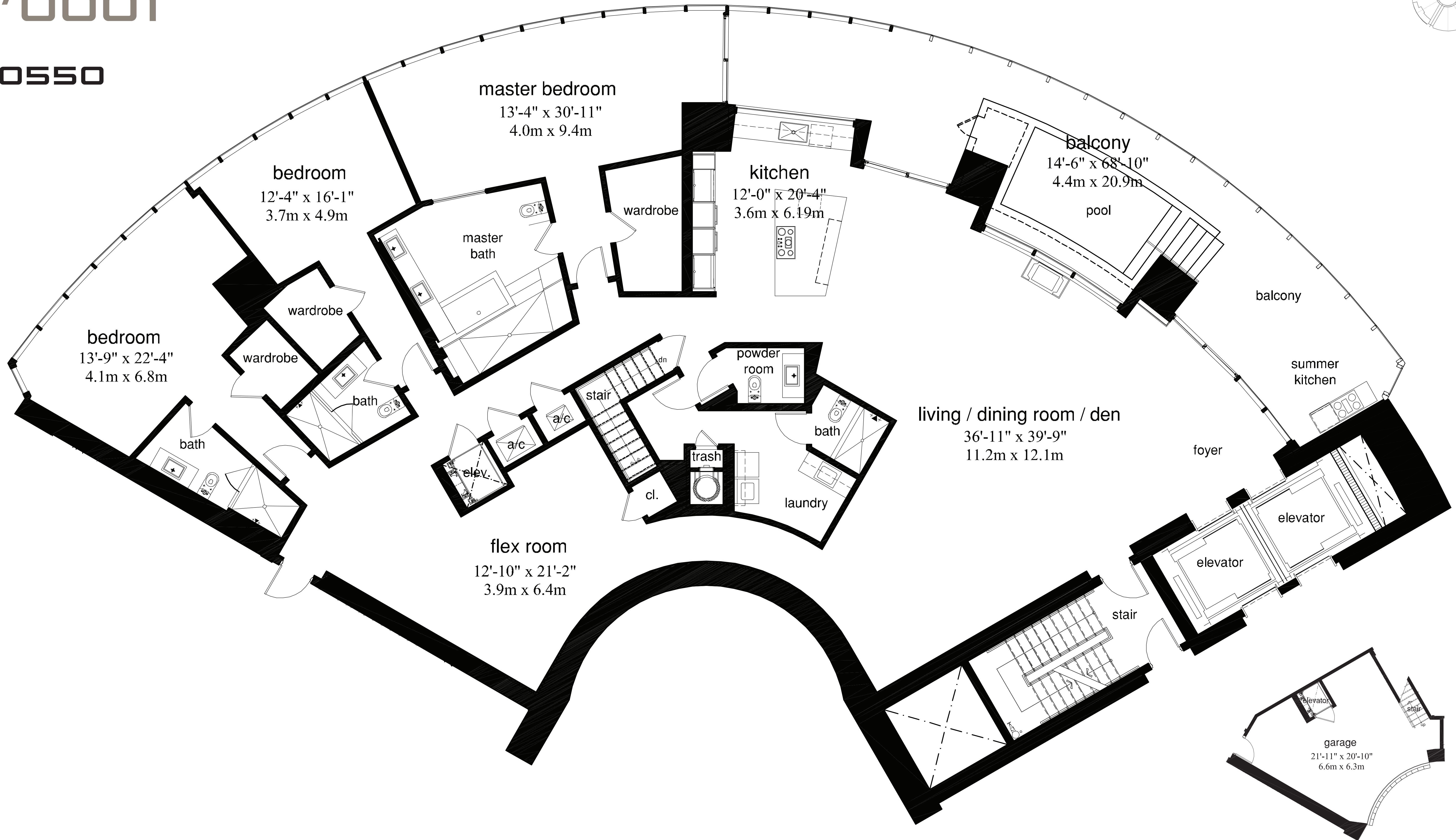

Area	SQ FT	M ²
Interior	4,513	419.2
Balcony	831	77.2
Garage	569	52.8
Total	5,913	549.2

These drawings are conceptual only and are for the convenience of reference. They should not be relied upon as representations, express or implied, of the final detail of the residences. Units shown are examples of unit types and may not depict actual units. Stated square footages are ranges for a particular unit type and are measured to the exterior boundaries of the exterior walls and the centerline of interior demising walls and in fact vary from the area that would be determined by using the description and definition of the "Unit" set forth in the Declaration [which generally only includes the interior airspace between the perimeter walls and excludes interior structural components]. All depictions of appliances, plumbing fixtures, equipment, counters, soffits, floor coverings and other matters of detail are conceptual only and are not necessarily included in each Unit. Consult your Agreement and the Prospectus for the items included with the Unit. Dimensions and square footage are approximate, will vary with specific unit type, and may vary with actual construction. Additionally, measurements of rooms set forth on any floor plan are nominal and generally taken at the greatest points of each given room (as if the room were a perfect rectangle), without regard for any cutouts. Unit orientation and windows (including number, size, orientation and awnings), balcony/lanais (including configuration, size and railing/balustrade), structure and mechanical chases may vary. The developer expressly reserves the right to make modifications, revisions, and changes it deems desirable in its sole and absolute discretion and without notice.

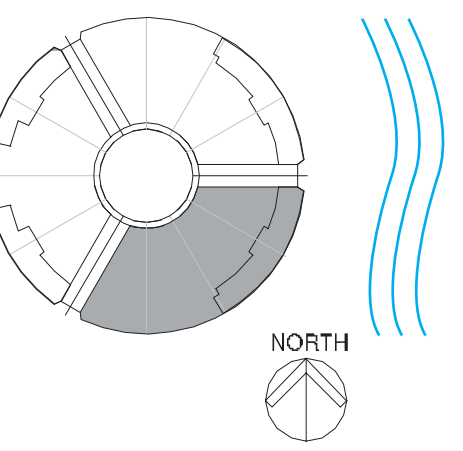

P'0880 [LOWER]

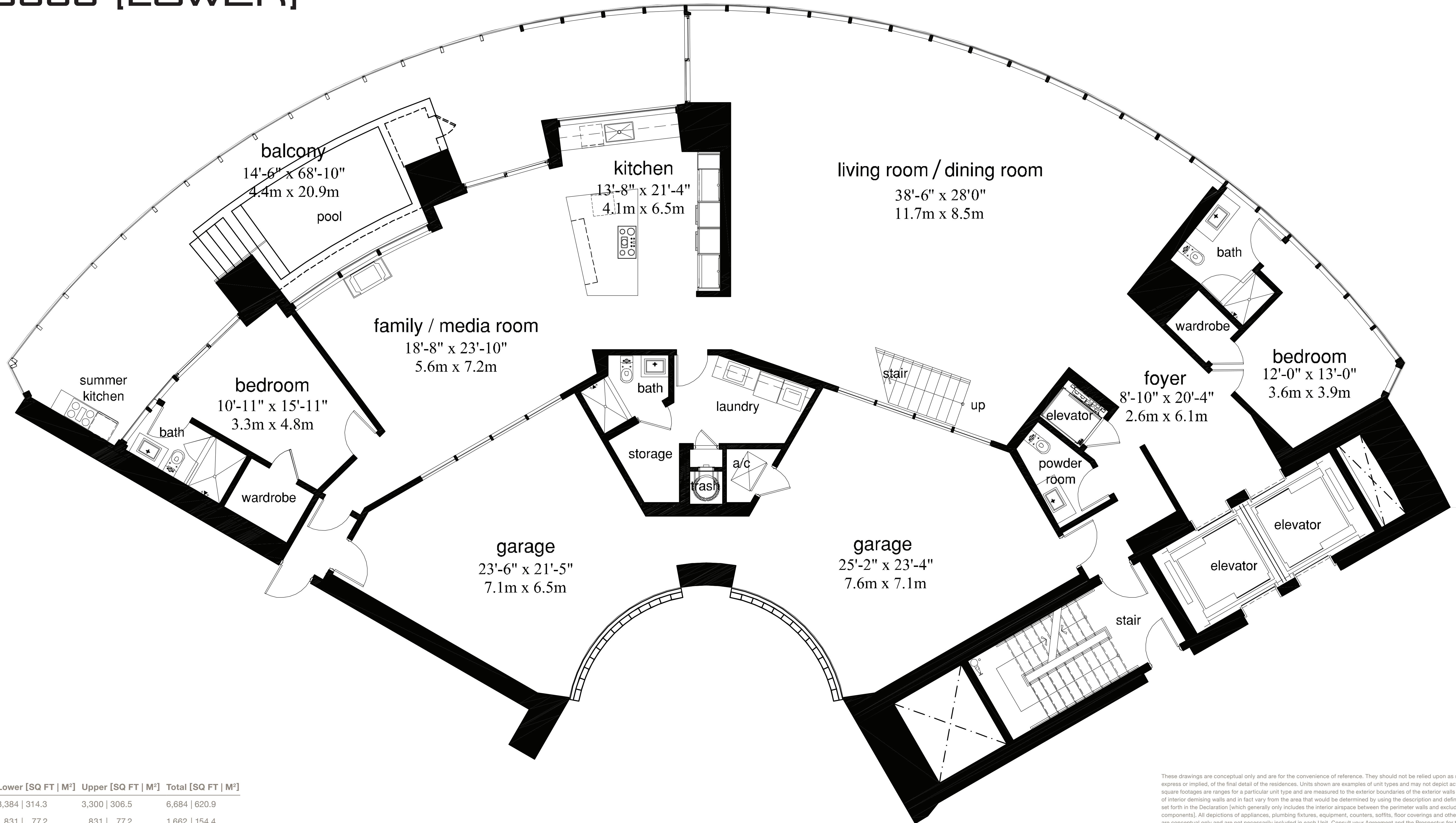

Area	Lower [SQ FT M ²]	Upper [SQ FT M ²]	Total [SQ FT M ²]
Interior	3,384 314.3	3,300 306.5	6,684 620.9
Balcony	831 77.2	831 77.2	1,662 154.4
Garage	1,128 104.8		1,128 104.8
Total	5,343 496.3	4,131 383.7	9,474 880.1

These drawings are conceptual only and are for the convenience of reference. They should not be relied upon as representations, express or implied, of the final detail of the residences. Units shown are examples of unit types and may not depict actual units. Stated square footages are ranges for a particular unit type and are measured to the exterior boundaries of the exterior walls and the centerline of interior demising walls and in fact vary from the area that would be determined by using the description and definition of the "Unit" set forth in the Declaration (which generally only includes the interior airspace between the perimeter walls and excludes interior structural components). All depictions of appliances, plumbing fixtures, equipment, counters, soffits, floor coverings and other matters of detail are conceptual only and are not necessarily included in each Unit. Consult your Agreement and the Prospectus for the items included with the Unit. Dimensions and square footage are approximate, will vary with specific unit type, and may vary with actual construction. Additionally, measurements of rooms set forth on any floor plan are nominal and generally taken at the greatest points of each given room (as if the room were a perfect rectangle), without regard for any cutouts. Unit orientation and windows (including number, size, orientation and awnings), balcony/lanais (including configuration, size and railing/balustrade), structure and mechanical chases may vary. The developer expressly reserves the right to make modifications, revisions, and changes it deems desirable in its sole and absolute discretion and without notice.

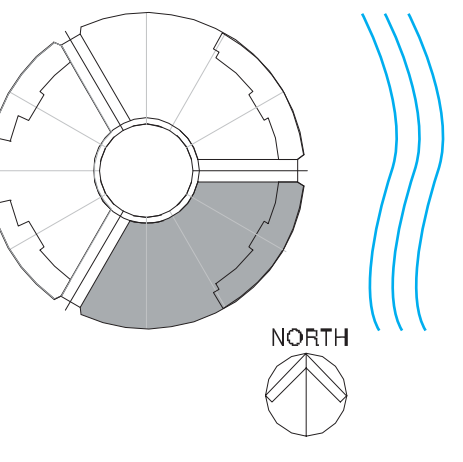

P'0880 [UPPER]

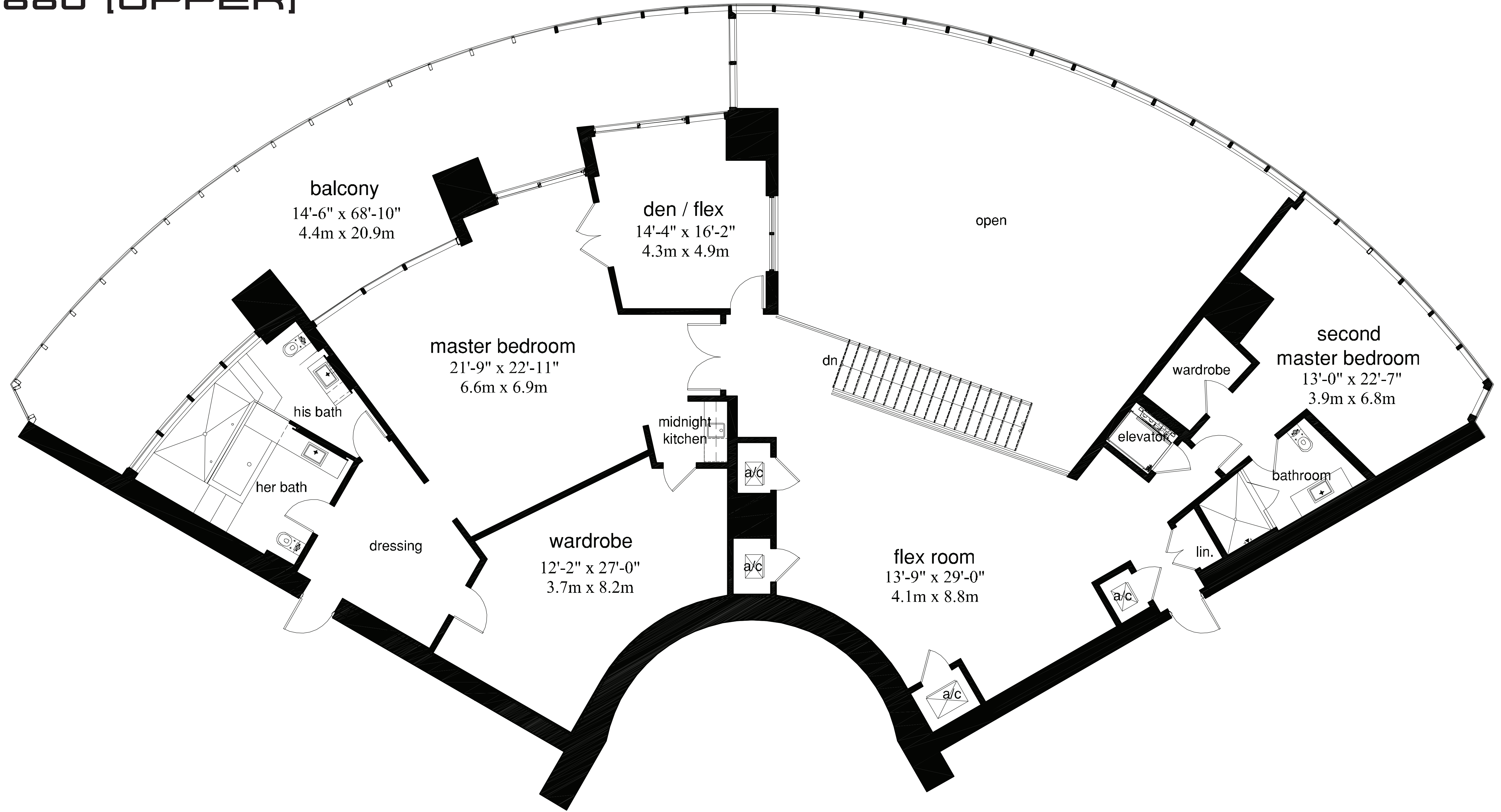

Area	Lower [SQ FT M ²]	Upper [SQ FT M ²]	Total [SQ FT M ²]
Interior	3,384 314.3	3,300 306.5	6,684 620.9
Balcony	831 77.2	831 77.2	1,662 154.4
Garage	1,128 104.8		1,128 104.8
Total	5,343 496.3	4,131 383.7	9,474 880.1

These drawings are conceptual only and are for the convenience of reference. They should not be relied upon as representations, express or implied, of the final detail of the residences. Units shown are examples of unit types and may not depict actual units. Stated square footages are ranges for a particular unit type and are measured to the exterior boundaries of the exterior walls and the centerline of interior demising walls and in fact vary from the area that would be determined by using the description and definition of the "Unit" set forth in the Declaration [which generally only includes the interior airspace between the perimeter walls and excludes interior structural components]. All depictions of appliances, plumbing fixtures, equipment, counters, soffits, floor coverings and other matters of detail are conceptual only and are not necessarily included in each Unit. Consult your Agreement and the Prospectus for the items included with the Unit. Dimensions and square footage are approximate, will vary with specific unit type, and may vary with actual construction. Additionally, measurements of rooms set forth on any floor plan are nominal and generally taken at the greatest points of each given room [as if the room were a perfect rectangle], without regard for any cutouts. Unit orientation and windows (including number, size, orientation and awnings), balcony/lanais (including configuration, size and railing/balustrade), structure and mechanical chases may vary. The developer expressly reserves the right to make modifications, revisions, and changes it deems desirable in its sole and absolute discretion and without notice.

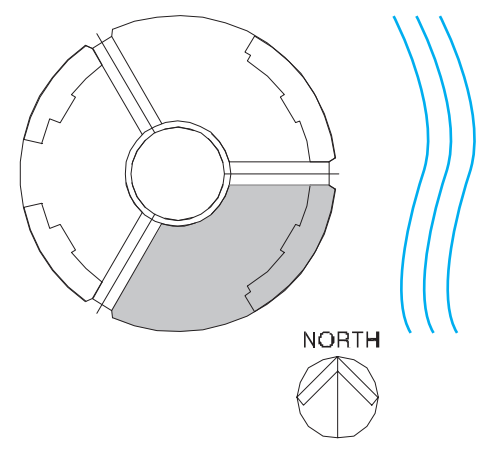

P'1571

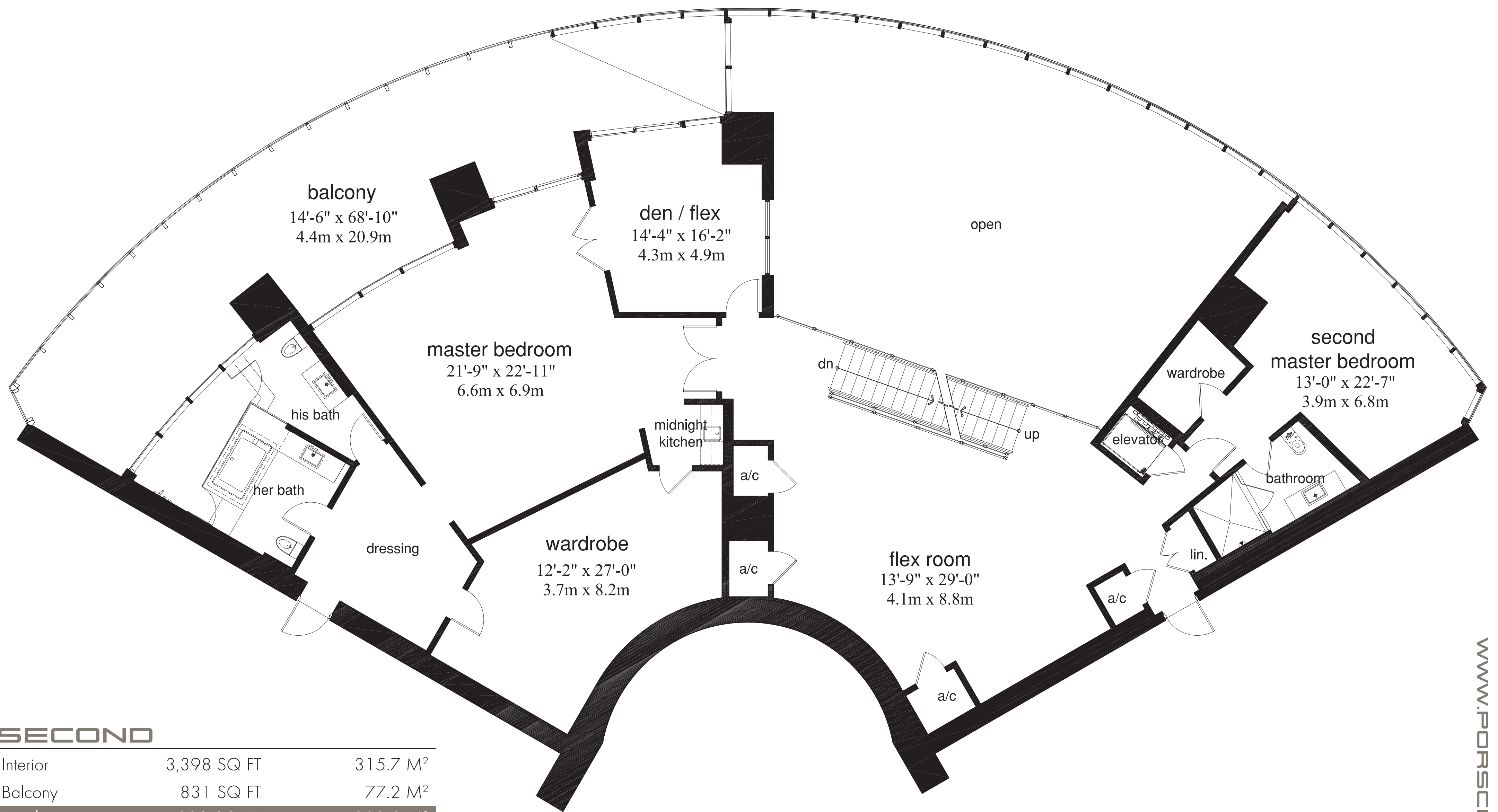

SECOND

Interior	3,398 SQ FT	315.7 M ²
Balcony	831 SQ FT	77.2 M ²
Total	4,229 SQ FT	392.9 M²

WWW.PORSCHE-DESIGN.COM/TOWERMIAMI/

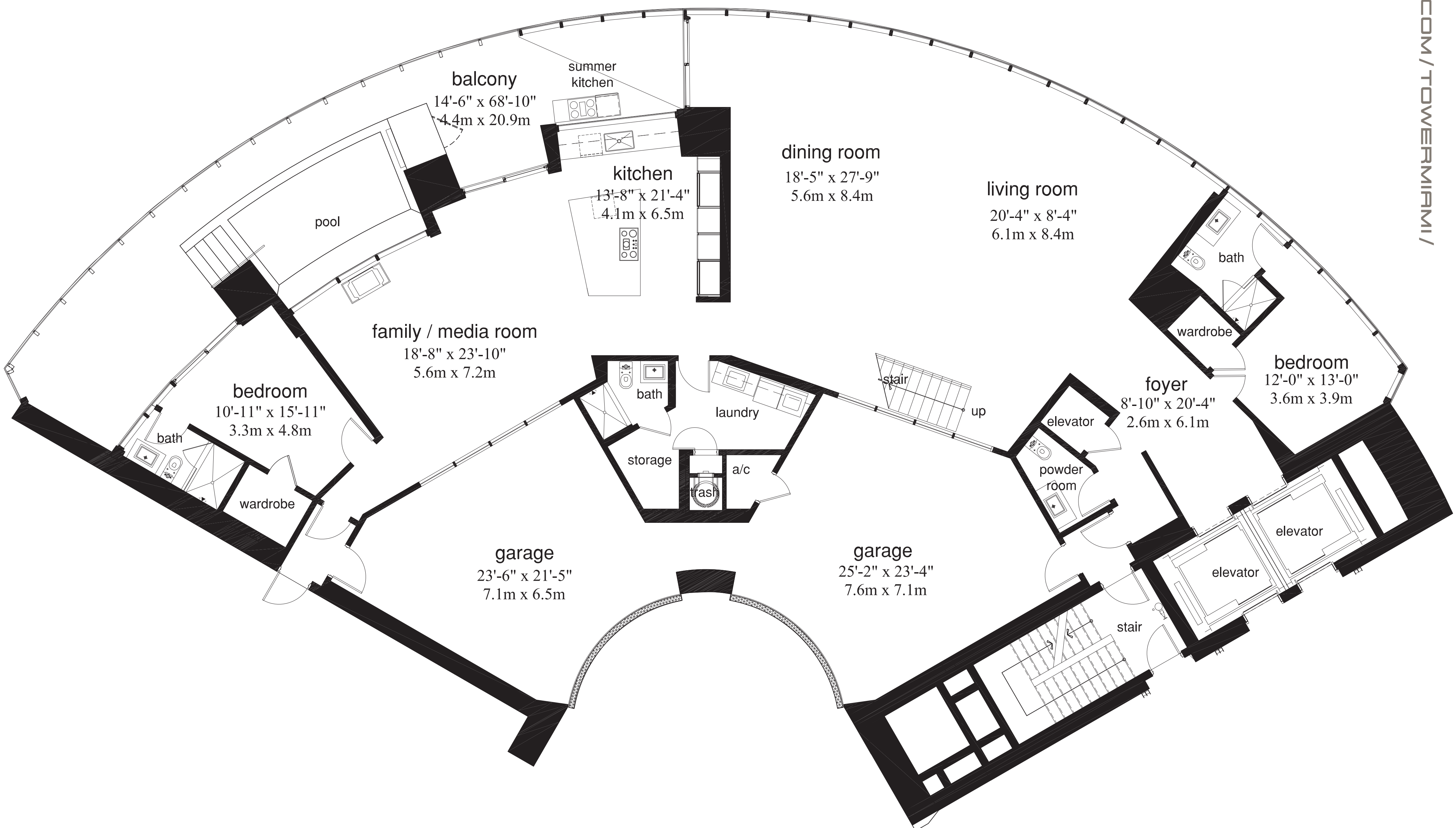

FIRST

Interior	3,384 SQ FT	314.3 M ²
Balcony	831 SQ FT	77.2 M ²
Garage	1,128 SQ FT	104.8 M ²
Total	5,343 SQ FT	496.3 M²

TOTAL

Interior	9,560 SQ FT	888.2 M ²
Balcony	6,227 SQ FT	578.5 M ²
Garage	1,128 SQ FT	104.8 M ²
Total	16,915 SQ FT	1,571.5 M²

These drawings are conceptual only and are for the convenience of reference. They should not be relied upon as representations, express or implied, of the final detail of the residences. Units shown are examples of unit types and may not depict actual units. Stated square footages are ranges for a particular unit type and are measured to the exterior boundaries of the exterior walls and the centerline of interior demising walls and in fact vary from the area that would be determined by using the description and definition of the "Unit" set forth in the Declaration (which generally only includes the interior airspace between the perimeter walls and excludes interior structural components). All depictions of appliances, plumbing fixtures, equipment, counters, soffits, floor coverings and other matters of detail are conceptual only and are not necessarily included in each Unit. Consult your Agreement and the Prospectus for the items included with the Unit. Dimensions and square footage are approximate, will vary with specific unit type, and may vary with actual construction. Additionally, measurements of rooms set forth on any floor plan are nominal and generally taken at the greatest points of each given room [as if the room were a perfect rectangle], without regard for any cutouts. Unit orientation and windows [including number, size, orientation and awnings], balcony/lanais [including configuration, size and railing/balustrade], structure and mechanical chases may vary. The developer expressly reserves the right to make modifications, revisions, and changes it deems desirable in its sole and absolute discretion and without notice.

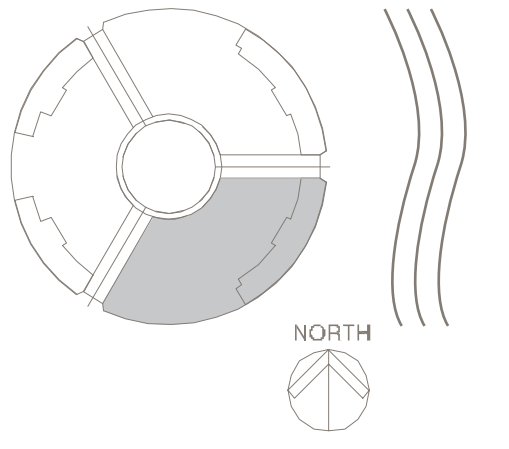

P'1571

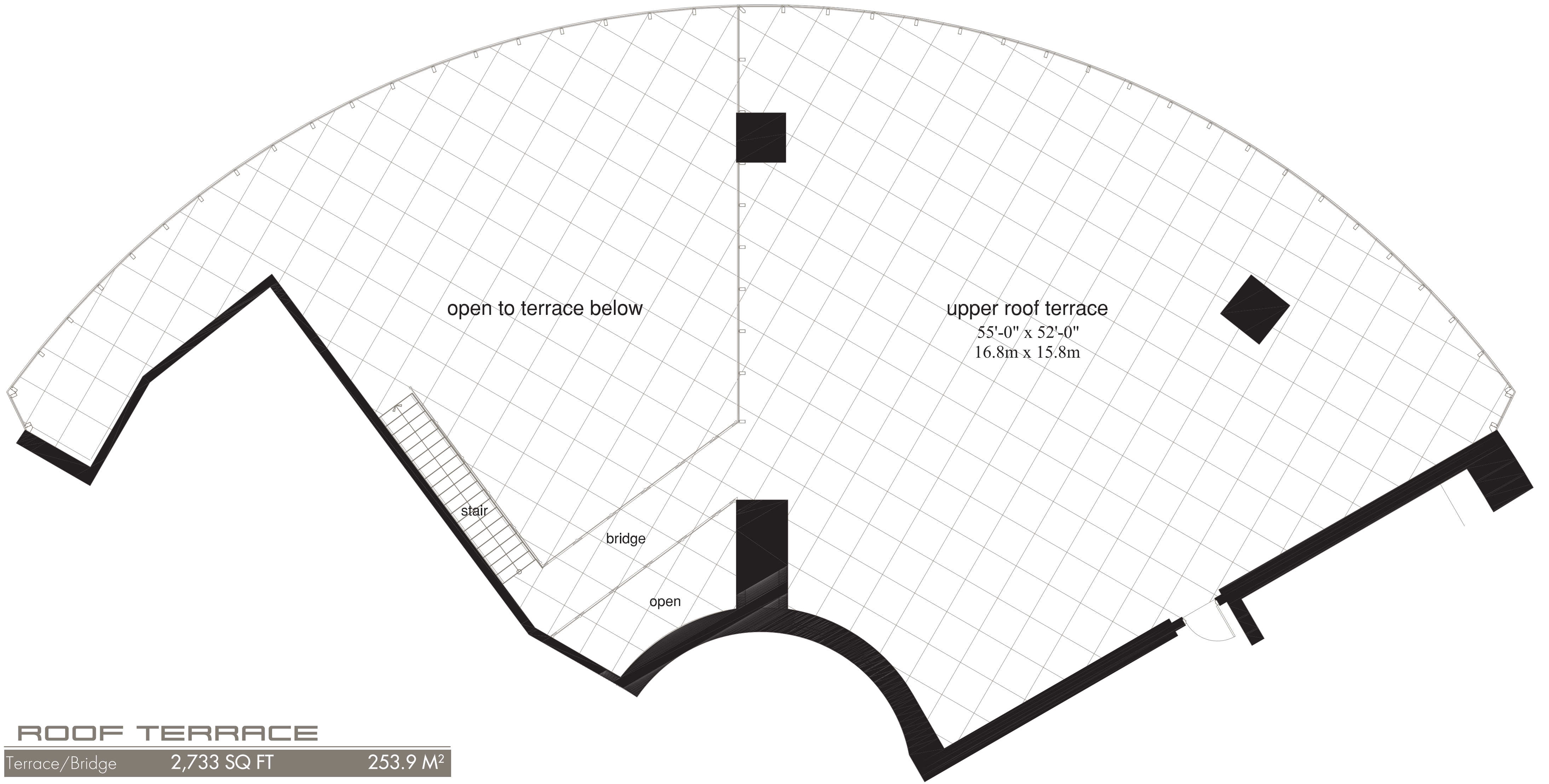

ROOF TERRACE

Terrace/Bridge	2,733 SQ FT	253.9 M ²
----------------	-------------	----------------------

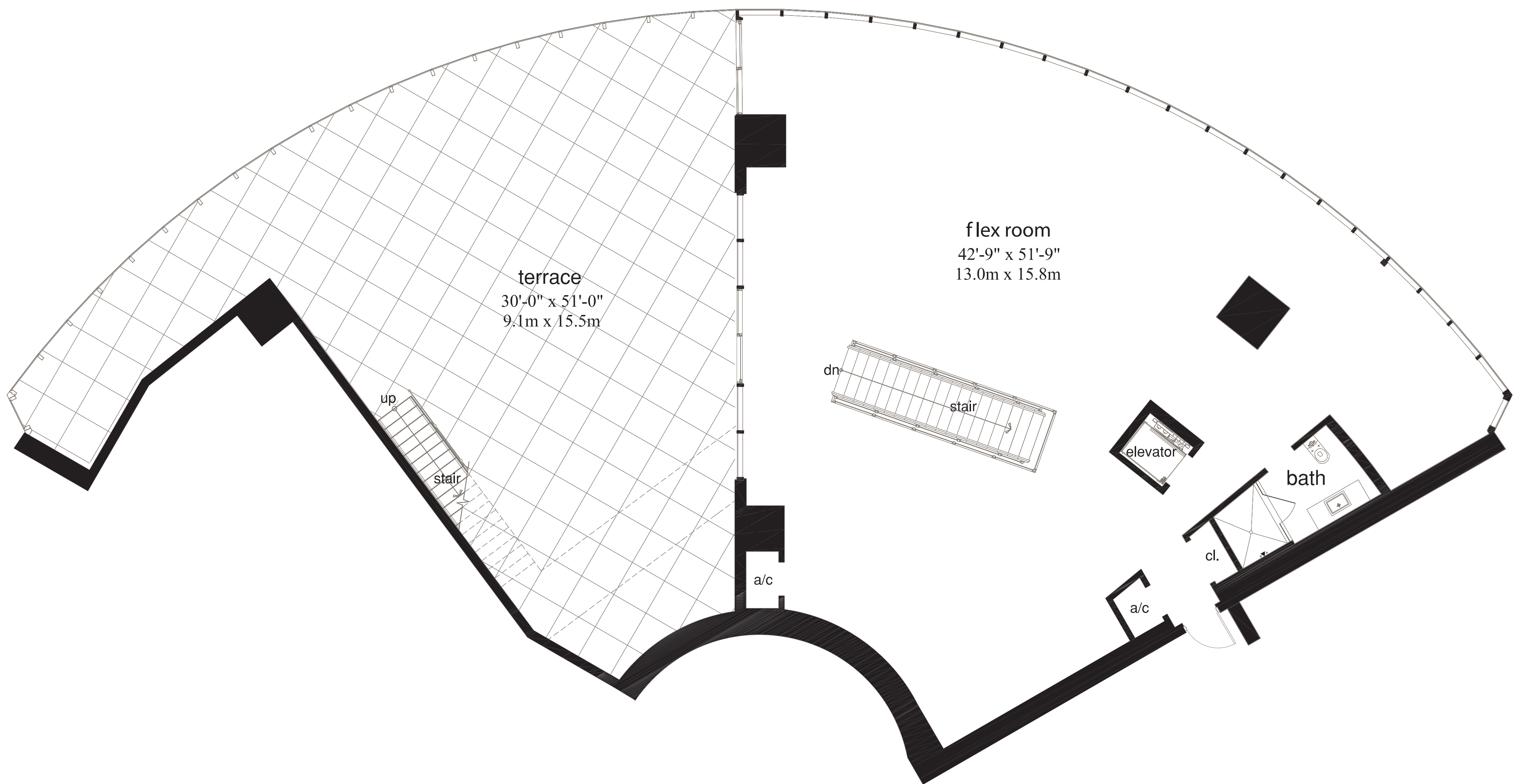

THIRD

Interior	2,778 SQ FT	258.1 M ²
Balcony	1,832 SQ FT	170.2 M ²
Total	4,610 SQ FT	428.3 M²

TOTAL

Interior	9,560 SQ FT	888.2 M ²
Balcony	6,227 SQ FT	578.5 M ²
Garage	1,128 SQ FT	104.8 M ²
Total	16,915 SQ FT	1,571.5 M²

These drawings are conceptual only and are for the convenience of reference. They should not be relied upon as representations, express or implied, of the final detail of the residences. Units shown are examples of unit types and may not depict actual units. Stated square footages are ranges for a particular unit type and are measured to the exterior boundaries of the exterior walls and the centerline of interior demising walls and in fact vary from the area that would be determined by using the description and definition of the "Unit" set forth in the Declaration (which generally only includes the interior airspace between the perimeter walls and excludes interior structural components). All depictions of appliances, plumbing fixtures, equipment, counters, soffits, floor coverings and other matters of detail are conceptual only and are not necessarily included in each Unit. Consult your Agreement and the Prospectus for the items included with the Unit. Dimensions and square footage are approximate, will vary with specific unit type, and may vary with actual construction. Additionally, measurements of rooms set forth on any floor plan are nominal and generally taken at the greatest points of each given room [as if the room were a perfect rectangle], without regard for any cutouts. Unit orientation and windows [including number, size, orientation and awnings], balcony/lanais [including configuration, size and railing/balustrade], structure and mechanical chases may vary. The developer expressly reserves the right to make modifications, revisions, and changes it deems desirable in its sole and absolute discretion and without notice.